



# 25-26 LINE UP

**ELEVATE  
YOUR SENSATIONS**

# CONTACTS

**JEAN-BAPTISTE PETIT**

Sales Director  
jb@zagskis.com  
+33 695 987 804

**THOMAS CHABOT**

France Sales Manager  
thomas@zagskis.com  
+33 7 85 80 22 36

# SUMMARY

ZAG UNIVERSE 02

 UBAC 12

ADRET 24

 SLAP 32

MATA 48

HARFANG 54

ACCESSORIES 64

# ICONIC BRAND

Freeride, Resort and Touring ski pioneer since 2002, ZAG has become a go-to choice for all terrain skiing.

ZAG skis are envisioned, designed and developed in the ZAGLAB in Chamonix, tested in the Alps, and recommended by mountain professionals. With our dedication to authenticity and sustainability, ZAG empowers passionate skiers to enjoy a unique experience on intuitive, high-performance skis.

“In 2011, ZAG launched the UBAC and pioneered ‘Freetouring’, bridging the gap between the worlds of ski touring and freeriding. This innovative ski quickly became a best seller. Since then, Bastien and the R&D team have been constantly improving the ‘ski feeling’ of this legendary ski.

For the 2025-26 season we decided to introduce the UBAC NEXT GENERATION, incorporating advanced technology and innovative design. Thanks to its new shape, cutting-edge materials and aspirational design, with this NEW UBAC you will experience the perfect blend of style and pleasure on all types of snow. This season we’ve also completely redesigned our most playful range, the SLAP. With eye-catching graphics and dynamic color schemes, this ski is perfect for skiers who want to embrace adventure and creativity. Talented artist Tommy brings a fresh, young, and urban flair to the slopes. Get ready to have fun with our new SLAP range, where art meets performance!

You are warmly invited to our newly revamped office in Chamonix! Come and try out our skis, visit our ZAG LAB, or just enjoy a chat in front of the fire. Enjoy your winter and be Happy Together.”

Caroline de Wailly CEO

# INNOVATIVE DESIGN

We've always been inspired by art and artists of all kinds and backgrounds. For the UBAC range we looked at the work of Gunta Stolz and her tapestry. We loved the way she was able to tell a story with shapes and colors.

This year we wanted to try something new, drawing a panoramic landscape and telling our own story. Drawing inspiration from our DNA, we used a part of our logo to draw the paths with curved or straight lines, mellow or steep mountains but always sharing your line with others. Our skis are designed for adventures - from mellow hills and mountain passes to sharper and steeper peaks, we've created our own mountain chain.

Last year, we worked with a new artist to design the SLAP 104 Lite. Listening to your feedback, we kept the flow going with Tommy Knuts to design the new SLAP range for this year.

The result is something unique. A diptych mixing abstract shapes with mountains, snow, trees and whatever your mind can imagine. Bringing back ZAG roots with illustrations but twisting it with our color block DNA.

# ADVANCED TECHNOLOGY

Our two engineers Bastien Saillard and Paul Chevalot design our skis in the ZAG Lab located in Chamonix with the goal of satisfying the many tastes of our customers. Always hungry to improve, they spend their time studying innovative shapes, materials, and constructions.

"We are compelled to endlessly innovate by creating skis that are increasingly intuitive, comfortable, high performing, and that provide skiers with a unique riding experience. With our concept store at the foot of Grands Montets, our playground is in our backyard. Being so connected with the environment is a true source of inspiration. This is what allows us to create such comfortable and high-performing skis."

Bastien Saillard, Director of Research and Development

The ZAG LAB allows our engineers to create prototypes in record time, and its prime location in Chamonix lets us test them right away and make improvements accordingly. The team was able to test the skis on all types of snow. This year, they developed the MATA, a new all-mountain ski that allows unique carving sensations.

This connection to nature pushes ZAG's R&D team to create products that are respectful to the environment, especially through the use of new materials or designs. The ZAGREEN Program represents ZAG's commitment to sustainability.

# ZAGREEN PROGRAM

Aware that our playground is threatened and that the quality of the air in the valley is more and more an issue of discussion, ZAG has launched the ZAGreen Program. Created in 2017, the aim of this program is to reduce the environmental impact of the ski industry. The actions that will be done will concern the manufacturing of the products, the way we practice skiing and also the daily life in our office. In addition to the measures involving only the company, the aim is to increase awareness among the whole community about the environmental challenge that is the air quality in our valley. ZAGreen is a project that hopes to be heard and also to involve more actors of this beautiful place.

All of our materials and products are developed in collaboration with our suppliers to reduce the impact while keeping the performance, quality and durability of our skis unchanged.

For example, our thermoplastics are made from recycled materials and produced in a responsible way (REACH, reductions of waste,...).

The enrolment of the ski-touring line in the project 1% for the planet also helps ZAG reaching its goal : preserving its playground. In 2021, ZAG redistributed this percentage to Mountain Wilderness. In 2023, we are giving the 1% to Mountain Riders and the cleaning project «Adopt ton spot», in Chamonix (La Flégère).



#### BIO SOURCED RESIN

We have used a resin which is 33% bio-sourced to produce the ADRET range since 2016. 25 % for the other range. It is mainly composed of oil produced with oil plants.



#### MATERIALS FROM EUROPE

Constant research to find the most performing and eco-responsible materials.

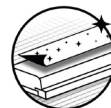

#### TOPSHEET

Our topsheet are made of 50% bio-sourced materials.

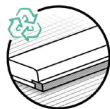

#### RECYCLED EDGES

Thick edges on alpine skis on thin edges on ultra-light skis. The edges are from recycled metal.



#### WOODEN CORE

Quality gain. Ensures the durability. Respects the forests sustainable management.



#### RECYCLED BASE

Up to 85% of recycled materials on black base only.



#### COTTON BAGS

We switched to bio cotton bags packaging in 2020 to stop producing around 1600kg of plastic each year.







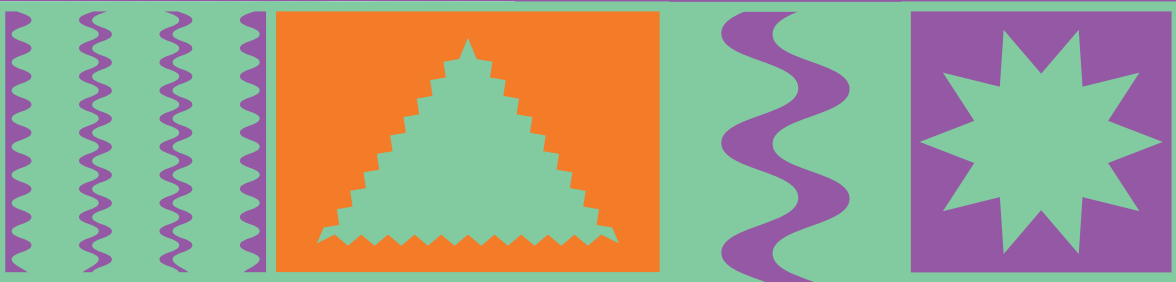

**HAPPY**

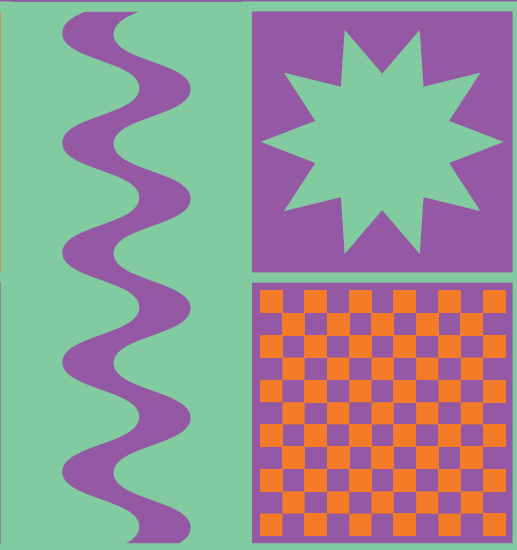

**T\*GETHER**

Inspired by 70s surf culture, we're shaking up the traditional vision of ski touring with an unconventional approach. A perfect invitation to explore the outdoors between friends, where fun comes first!

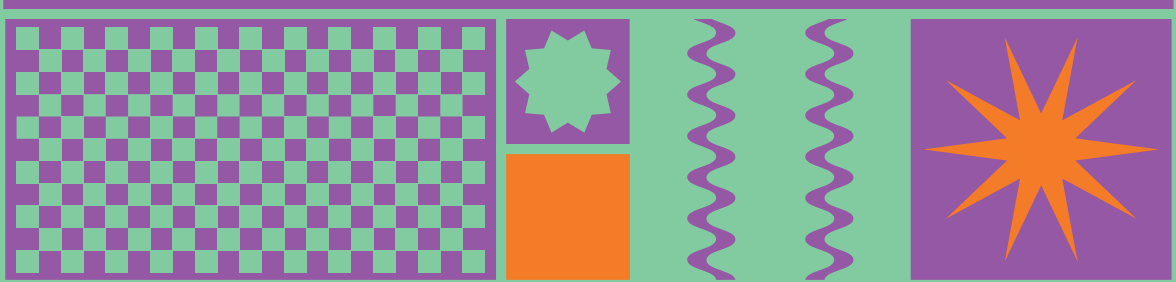

**ZAG™**  
TOURING

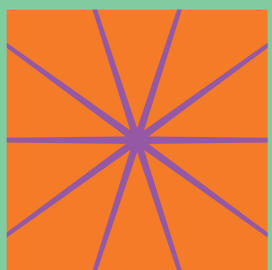



E

O

L

T

I

O



ALL THE

NEW

25

26

**25.26  
LIGHT  
TOURING**

**UB**

A

new NEW  
new

89

95

102

108

# NEW LIGHT CONSTRUCTION

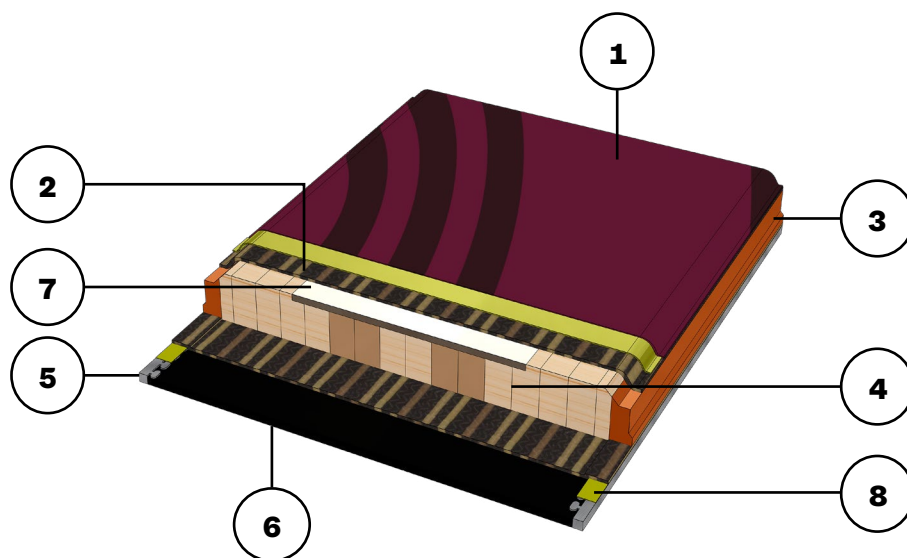

Built with the best ratio between lightness and skiability to give ski tourers the closest feeling to a freeride ski possible. The wood core saves a few extra grams without impacting the feeling underfoot or the resistance of the material. Thick edges and ABS sidewalls make the UBAC range durable and impact resistant.

- 1 - New polyamide topsheet : 50% bio-sourced, durability +++.
- 2 - High resistance carbon & glass fiber : Skiability and lightness.
- 3 - New semi-Cap construction : ABS sidewalls for energy transmission.
- 4 - New poplar-paulownia wood core : Lightness & response.
- 5 - High resistance edges : Durability.
- 6 - Recycled sintered bases : Slide, durability.
- 7 - Titanal plate : Anti-pullout system for light bindings.
- 8 - Rubber : Vibration dampening.



new  
**NEW**  
new

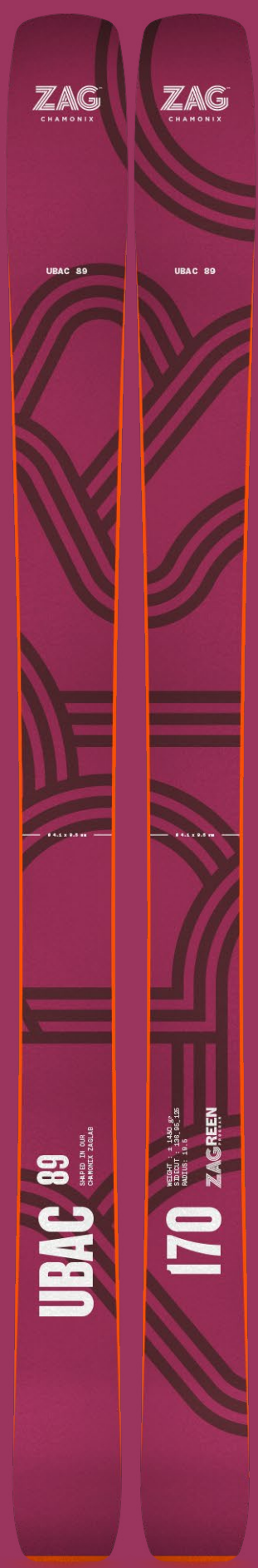



# UBAC 89

## As far as you want !

The lightest and narrower of the range, allowing you to go for the longest and farest run in the backcountry. Keeping the UBAC dna of a freeride feel and great downhill abilities. With great flex stiffness, the UBAC 89 is also a beast in hard pack snow and has a strong grip for the steepest slopes.

GENDER	LENGTH	DIMENSIONS	RADIUS	WEIGHT (-/+)
LADY	155	121 / 89 / 107	16	± 1.150
LADY	162	122.5 / 89 / 108	17	± 1.200
LADY & MAN	169	123.5 / 89 / 109	18	± 1.280
MAN	176	125 / 89 / 110	19	± 1.300
MAN	183	126 / 89 / 111	20	± 1.400

### SENSATIONS

Hard snow aptitude



Deep snow aptitude

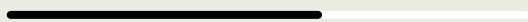

Uphill aptitude

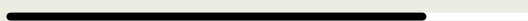

Ease of use

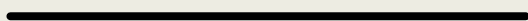

### SHAPE

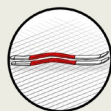

MEDIUM CAMBER

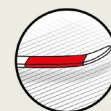

LIGHT DOUBLE ROCKER



STIFF FLEX



MEDIUM CURVE RADIUS



### ZAGREEN PROGRAM



BIO SOURCED RESIN

25% bio-sourced resin



TOPSHEET

50% bio-sourced material

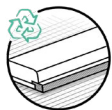

RECYCLED EDGES

The edges are from recycled metal



COTTON BAG

Bio cotton bags packaging



MATERIALS EUROPE

Most performing and eco-responsible materials



RECYCLED BASE

85% recycled black base

new - new - new  
**NEW**



# UBAC 95

**The favourite ski of your favourite guide.**

In one word : VERSATILITY. The UBAC 95 is the to go choice of mountain guide for one reason it can do it all. 95mm underfoot to enjoy every terrain in a light package for long hikes. The new shape of the UBAC 95 makes it even more able on changing snow, still super fun and accessible but stiffer flex to go down fast.

GENDER	LENGTH	DIMENSIONS	RADIUS	WEIGHT (-/+)
LADY	158	128.5 / 95 / 113	16	± 1.240
LADY	166	129 / 95 / 114	17	± 1.300
LADY & MAN	173	129.5 / 95 / 114.5	18	± 1.360
MAN	178	130 / 95.5 / 115	19	± 1.430
MAN	185	131 / 96 / 116	20	± 1.490

## SENSATIONS

Hard snow aptitude



Deep snow aptitude



Uphill aptitude

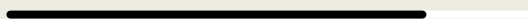

Ease of use



## CONSTRUCTION & SHAPE

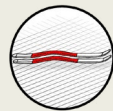

**MEDIUM CAMBER**

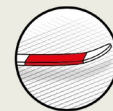

**LIGHT DOUBLE ROCKER**



**STIFF FLEX**



**SHORT CURVE RADIUS**



## ZAGREEN PROGRAM



**BIO SOURCED RESIN**

25% bio-sourced resin



**TOPSHEET**

50% bio-sourced material

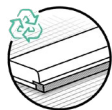

**RECYCLED EDGES**

The edges are from recycled metal



**COTTON BAG**

Bio cotton bags packaging



**MATERIALS EUROPE**

Most performing and eco-responsible materials



**RECYCLED BASE**

85% recycled black base

new  
**NEW**  
new



ZAG  
CHAMONIX

ZAG  
CHAMONIX

UBAC 96

UBAC 96

UBAC 102  
SHAPED IN OUR  
CHAMONIX ZAG LAB

SHAPED IN OUR  
CHAMONIX ZAG LAB  
RADIUS: 1400 & 1400  
RADIUS: 1500 & 1500

175

ZAGREEN

# UBAC 102

## Is this a freeride ski?

You are this one friend in the group who always wants to go fast, jump and ride aggressively? The UBAC 102 is your best pick then, if you like larger skis and you are a powder seeker, this one won't disappoint you. You probably won't see the difference with your traditional freeride skis and get a bunch of fun.

GENDER	LENGTH	DIMENSIONS	RADIUS	WEIGHT (-/+)
UNISEX	168	136 / 102 / 121	18	± 1.420
UNISEX	175	137 / 102 / 121	19	± 1.510
UNISEX	181	138 / 102 / 123	20	± 1.600
UNISEX	188	139 / 102 / 124	21	± 1.690

### SENSATIONS

Hard snow aptitude



Deep snow aptitude



Uphill aptitude

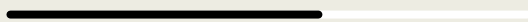

Ease of use

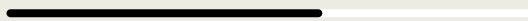

### CONSTRUCTION & SHAPE

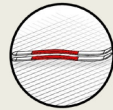

LOW CAMBER



DOUBLE ROCKER



STIFF FLEX



MEDIUM CURVE RADIUS

Tail 20%      Rocker      Tip 30%



### ZAGREEN PROGRAM



BIO SOURCED RESIN

25% bio-sourced resin

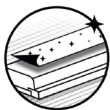

TOPSHEET

50% bio-sourced material

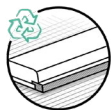

RECYCLED EDGES

The edges are from recycled metal



COTTON BAG

Bio cotton bags packaging



95% MATERIALS EUROPE

Most performing and eco-responsible materials



RECYCLED BASE

85% recycled black base

new  
**NEW**  
new

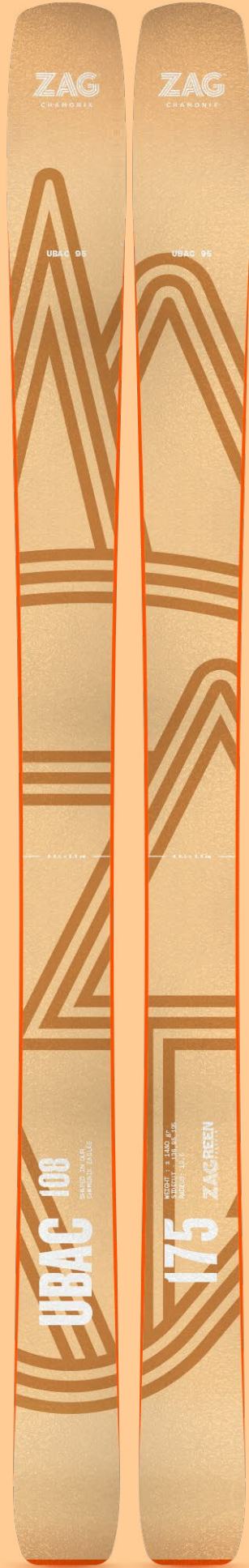

# UBAC 108

## Powder alert !

Replacing the UBAC 112, with new shape and construction the brand new UBAC 108 is made for those amazing days, light and deep powder ready to surf. The larger one of the range letting you enjoy the best backcountry days of the season.

GENDER	LENGTH	DIMENSIONS	RADIUS	WEIGHT (-/+)
UNISEX	173	140 / 108 / 126	19	± 1.640
UNISEX	180	141.5 / 108 / 127	20	± 1.700
UNISEX	188	143 / 108 / 128	21	± 1.740

### SENSATIONS

Hard snow aptitude



Deep snow aptitude

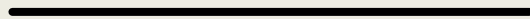

Uphill aptitude

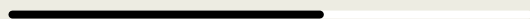

Ease of use



### CONSTRUCTION & SHAPE



LOW CAMBER

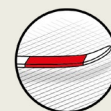

DOUBLE ROCKER



STIFF FLEX



MEDIUM CURVE RADIUS

Tail 30%      Rocker      Tip 40%



### ZAGREEN PROGRAM



BIO SOURCED RESIN

25% bio-sourced resin



TOPSHEET

50% bio-sourced material

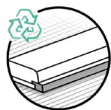

RECYCLED EDGES

The edges are from recycled metal



COTTON BAG

Bio cotton bags packaging



MATERIALS EUROPE

Most performing and eco-responsible materials



RECYCLED BASE

85% recycled black base

**25.26**

**ULTRA LIGHT  
TOURING**

# AND



REFIT

78

85

# ULTRA LIGHT CONSTRUCTION

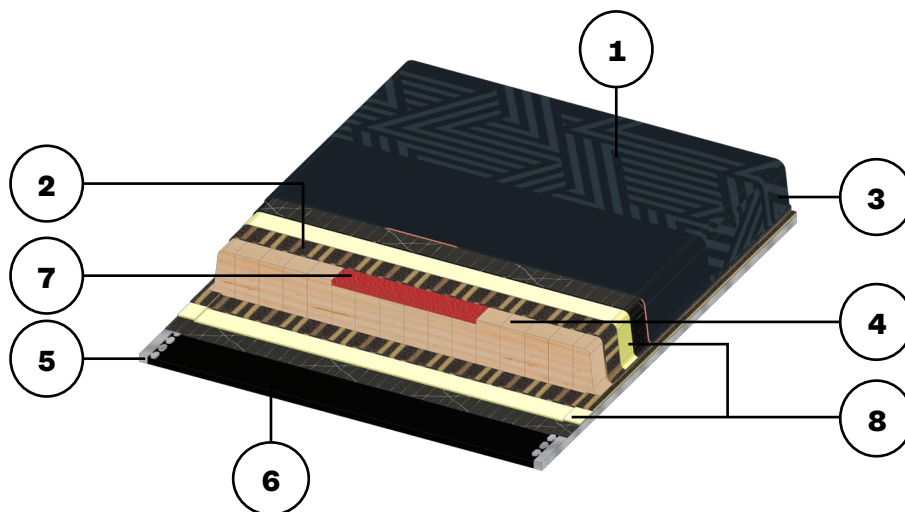

The combination of lightness and performance while being rigid in torsion and in flex, makes the ADRET exemplary in reliability. These are perfect characteristics for an ultra light touring ski! High resistance carbon fiber gives this ski the lightness and stiffness expected by the most demanding of ski tourers and is virtually unbreakable ! The rubber fiber absorbs vibrations adding to it's impeccable feeling on snow.

- 1 - Polyamide topsheet : 50% bio-sourced, durability and shiny colors.**
- 2 - High resistance carbon (62%) & glass fiber : Maximal resistance and lightness.**
- 3 - Cap construction : No ABS sidewalls for lightness.**
- 4 - Paulownia wood core : Lightness.**
- 5 - High resistance thin edges : Lightness.**
- 6 - Sintered bases : Slide, durability.**
- 7 - Phenol plate : Anti-pullout system for ultra light bindings.**
- 8 - Rubber : Vibration dampening.**

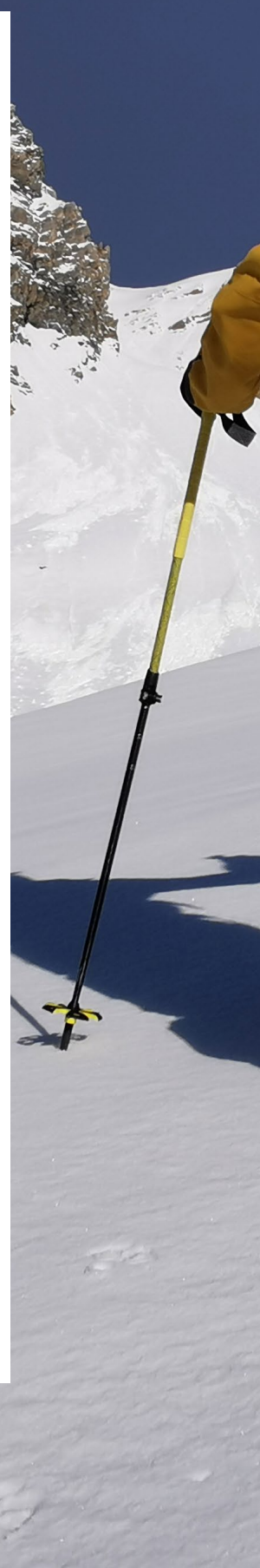



ZAG  
CHAMONIX

ZAG  
CHAMONIX

ADRET  
78

ADRET  
78

*Imported in Chamrousse, France*  
ZAG SKI EQUIPMENT  
100, rue de Chamrousse  
74100, CHAMMUSSE, FRANCE  
800 39 6212

*Imported in Chamrousse, France*  
ZAG SKI EQUIPMENT  
100, rue de Chamrousse  
74100, CHAMMUSSE, FRANCE  
800 39 6212

A

78

1080 GR

176

CLIMB HARD ON STEEP SLOPES

ZAGREEN  
TECHNOLOGY

ZAG  
CHAMONIX

ZAG  
CHAMONIX

# ADRET 78



**If you need to get home for lunch !**

An ultra-light ski that has excellent skiability for it's category. Torsionally stiff increases edge hold to give you that secure feeling in icy conditions on the downs or the ups. Dedicated for those who are looking for a ski imagined and developed for the steeps, ski mountaineering or ski touring excursions over multiple days. The ADRET 78 also suits those looking to add a mountaineering ski for training to their quiver.

GENDER	LENGTH	DIMENSIONS	RADIUS	WEIGHT (-/+)
UNISEX	165	110 / 78 / 93	20	0.960
UNISEX	170	111 / 78 / 94	21	1.020
UNISEX	176	112 / 78 / 95	22	1.080

## SENSATIONS

Hard snow aptitude



Deep snow aptitude



Uphill aptitude



Ease of use

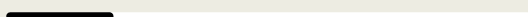

## SHAPE

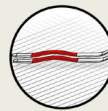

**STRONG CAMBER**

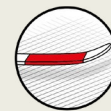

**PROGRESSIVE TIP**



**STRONG FLEX**



**LONG CURVE RADIUS**



## ZAGREEN PROGRAM



**BIO SOURCED RESIN**

33% bio-sourced resin



**TOPSHEET**

50% bio-sourced material

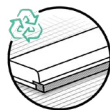

**RECYCLED EDGES**

The edges are from recycled metal



**COTTON BAG**

Bio cotton bags packaging



**MATERIALS EUROPE**

Most performing and eco-responsible materials

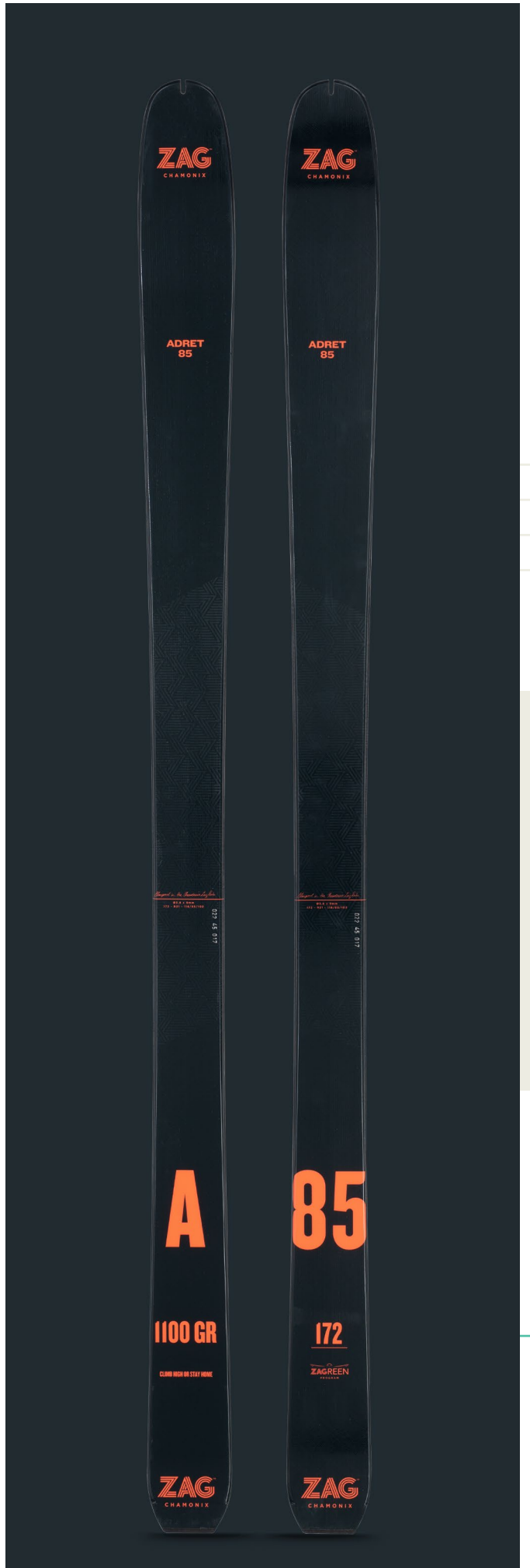

# ADRET 85



## Mountaineering in ultra-light mode.

The ADRET 85 is an ultra light ski imagined to perform as well for the downs. It's the touring ski of excellence that combines a great edge hold and performs well in all conditions. Fast touring, steeps, high mountain, expeditions... this ski isn't afraid of anything you want to throw at it.

GENDER	LENGTH	DIMENSIONS	RADIUS	WEIGHT (-/+)
LADY	155	114 / 85 / 99	18	0.960
LADY	160	115 / 85 / 100	19	1.000
LADY & MAN	166	115.5 / 85 / 101	20	1.030
MAN	172	116 / 85 / 102	21	1.100
MAN	178	117 / 85 / 103	22	1.200

### SENSATIONS

Hard snow aptitude



Deep snow aptitude



Uphill aptitude



Ease of use

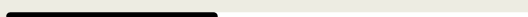

### CONSTRUCTION & SHAPE

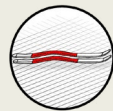

**STRONG CAMBER**

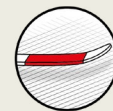

**PROGRESSIVE TIP**



**MEDIUM FLEX**



**LONG CURVE RADIUS**



### ZAGREEN PROGRAM



**BIO SOURCED RESIN**

33% bio-sourced resin



**TOPSHEET**

50% bio-sourced material

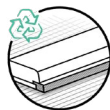

**RECYCLED EDGES**

The edges are from recycled metal



**COTTON BAG**

Bio cotton bags packaging



**MATERIALS EUROPE**

Most performing and eco-responsible materials

**25.26**  
**FREERIDE**

**S**

**L**

new - new  
**NEW**



A

92  
98  
104  
112  
JR  
LITE

# HEAVY DUTY LIGHT CONSTRUCTION

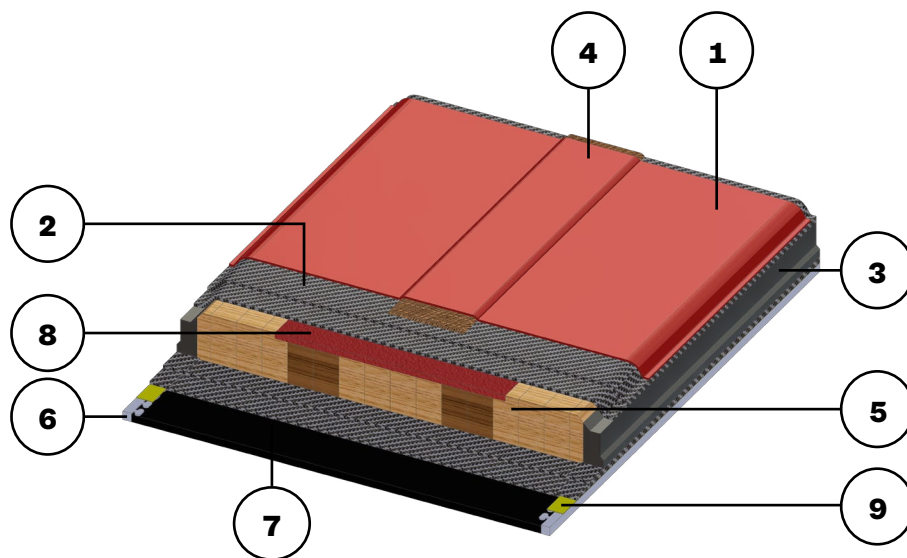

Lightness and power to hit the groomers and open fields of fresh pow. This construction uses multi-axial fiberglass, increasing its skiability and power by providing stiffness in torsion and flex. The goal was also to reduce the weight of these XXL skis, hence the combination of paulownia (lightness) and poplar (resistance). In the end, this construction creates a light and playful ski that's stable at high speeds and resistant over time !

- 1 - Polyamide topsheet : 50% bio-sourced, durability and shiny colors.
- 2 - Quadri-axial fiber : Pop and resistance.
- 3 - Semi-Cap construction : ABS sidewalls for energy transmission.
- 4 - Flax : Dampening properties.
- 5 - Poplar and Paulownia wood core : Lightness and resistance.
- 6 - High resistance edges : Durability.
- 7 - Sintered bases : Slide, durability.
- 8 - Phenol plate : Anti-pullout system for bindings.
- 9 - Rubber : Vibration dampening.

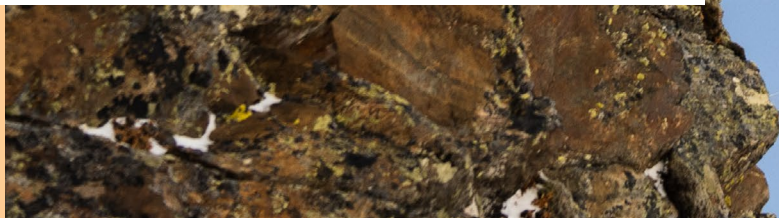



new - new - new  
**NEW**

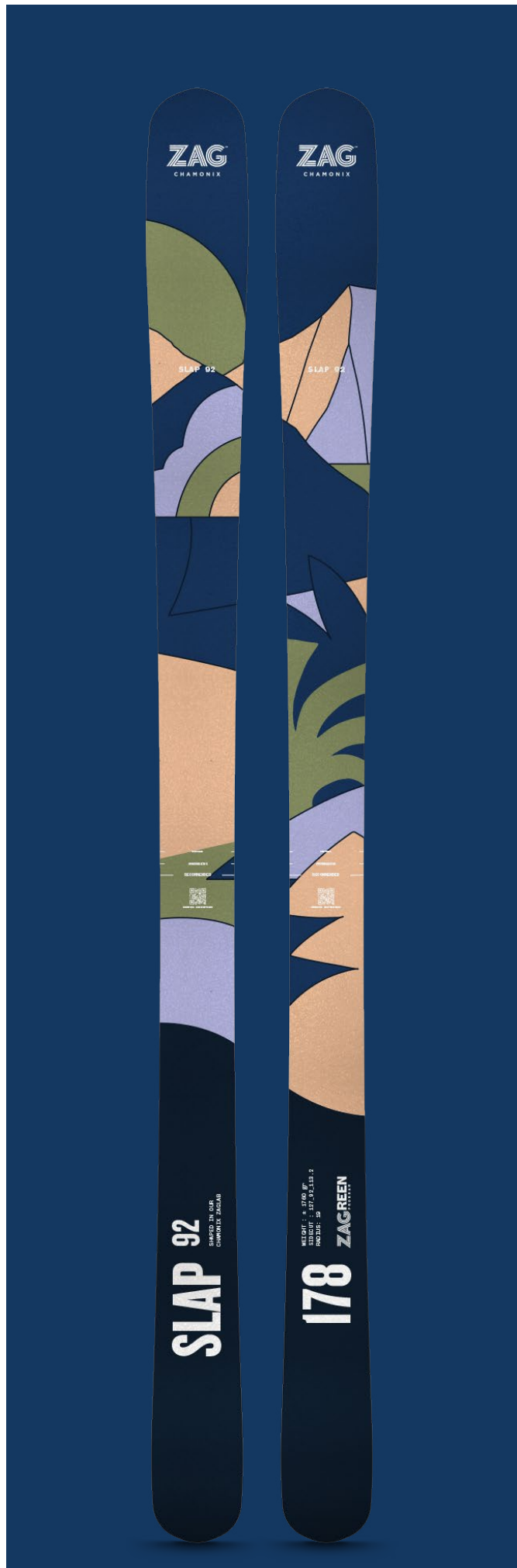
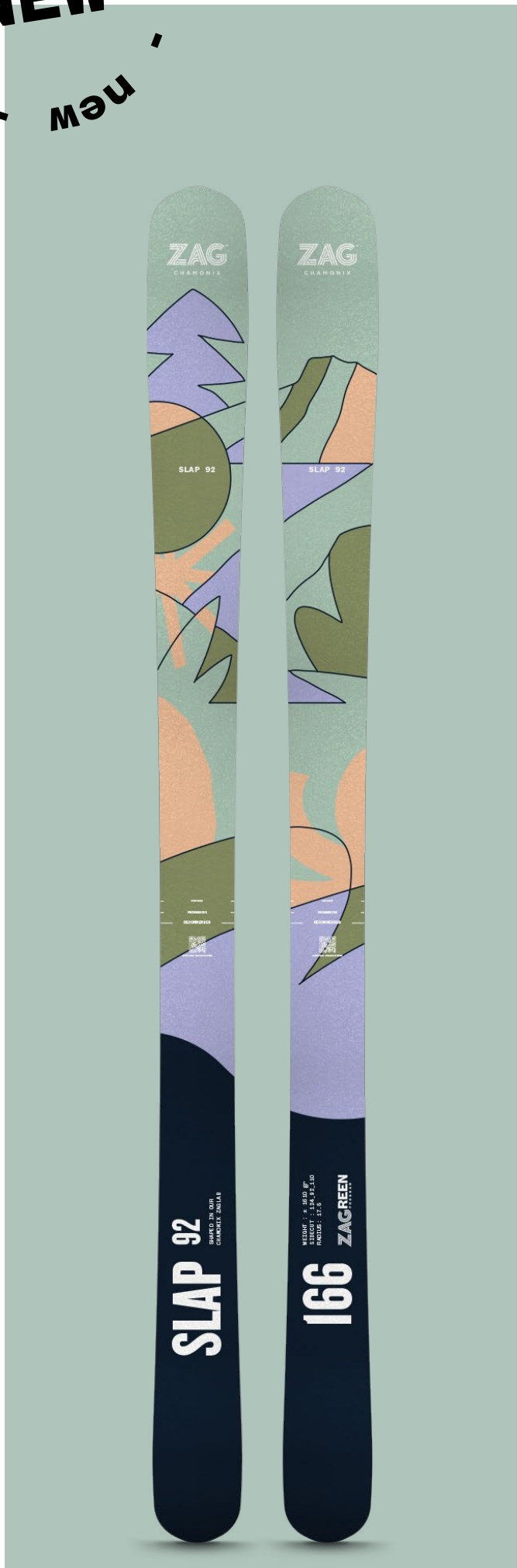

# SLAP 92

## Inbound fun !

A ski to fool around on inbounds, the SLAP 92 can do it all: carve, jump, jib. It's up to you to decide, be creative !

GENDER	LENGTH	DIMENSIONS	RADIUS	WEIGHT (-/+)
LADY	160	123 / 91 / 109	16.8	1.550
LADY	166	124 / 92 / 110	17.5	1.610
MAN	173	126 / 92 / 112.2	18.3	1.660
MAN	178	127 / 92 / 113.2	19	1.760
MAN	185	128 / 92 / 114	20	1.820

### SENSATIONS

Piste aptitude



Freeride aptitude



Uphill aptitude



Grip



Ease of use



### CONSTRUCTION & SHAPE

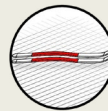

MEDIUM CAMBER

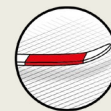

DOUBLE ROCKER



MEDIUM FLEX

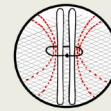

ADAPTIVE PIVOT CONTROL



### ZAGREEN PROGRAM



BIO SOURCED RESIN

25% bio-sourced resin



TOPSHEET

50% bio-sourced material

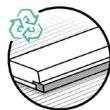

RECYCLED EDGES

The edges are from recycled metal



COTTON BAG

Bio cotton bags packaging



MATERIALS EUROPE

Most performing and eco-responsible materials



RECYCLED BASE

85% recycled black base

new - new - new  
**NEW**

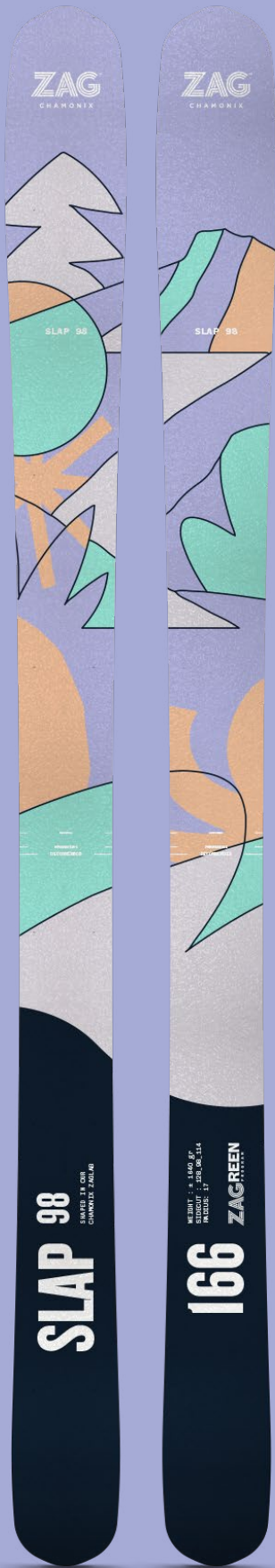

# SLAP 98

**If you didn't check the weather !**

Light and playful on all terrain, its excellent pivot point lets you switch from carving to freeride in a blink of an eye.

GENDER	LENGTH	DIMENSIONS	RADIUS	WEIGHT (-/+)
LADY	160	127 / 98 / 113	16	1.580
LADY	166	128 / 98 / 114	17	1.640
LADY & MAN	173	129 / 98 / 115	18.5	1.740
MAN	180	130 / 98 / 116.5	20	1.840
MAN	187	131 / 98 / 117	21	1.900

## SENSATIONS

Piste aptitude



Freeride aptitude

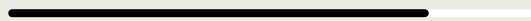

Uphill aptitude



Grip



Ease of use

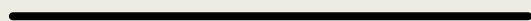

## CONSTRUCTION & SHAPE

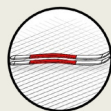

**MEDIUM  
CAMBER**

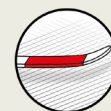

**DOUBLE  
ROCKER**



**MEDIUM  
FLEX**

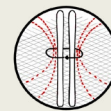

**ADAPTIVE  
PIVOT  
CONTROL**



## ZAGREEN PROGRAM



**BIO SOURCED RESIN**

25% bio-sourced resin



**TOPSHEET**

50% bio-sourced material

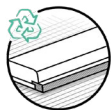

**RECYCLED EDGES**

The edges are from recycled metal



**COTTON BAG**

Bio cotton bags packaging



**MATERIALS  
EUROPE**

Most performing and eco-responsible materials



**RECYCLED  
BASE**

85% recycled black base

new  
**NEW**  
new



**SLAP 104**  
SHAPED BY OUR  
CHAMPION ZAGLARS

WE BUILT A SKI FOR  
THE NEW WAY TO  
TRAVEL IN THE  
**ZAGREEN**



# SLAP 104

**Take advantage of all the terrain has to offer !**

The SLAP 104 is the perfect tool to let you play with whatever the terrain throws your way. Its size and lightness will let you find those extra special freeride lines if you opt in for some hybrid touring bindings.

GENDER	LENGTH	DIMENSIONS	RADIUS	WEIGHT (-/+)
UNISEX	164	132.5 / 102 / 121	16	1.620
UNISEX	170	133.5 / 103 / 122	17	1.780
UNISEX	176	134 / 103 / 123	18.5	1.820
UNISEX	182	136 / 104 / 125.2	19	1.860
UNISEX	188	137 / 104 / 126	20	1.900

## SENSATIONS

Piste aptitude



Freeride aptitude

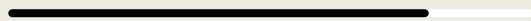

Uphill aptitude

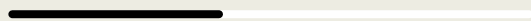

Grip



Ease of use

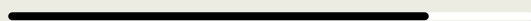

## CONSTRUCTION & SHAPE

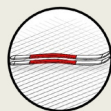

**MEDIUM CAMBER**

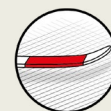

**DOUBLE ROCKER**



**MEDIUM FLEX**



**SHORT CURVE RADIUS**



## ZAGREEN



**BIO SOURCED RESIN**

25% bio-sourced resin



**TOPSHEET**

50% bio-sourced material

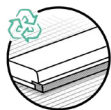

**RECYCLED EDGES**

The edges are from recycled metal



**COTTON BAG**

Bio cotton bags packaging



**MATERIALS EUROPE**

Most performing and eco-responsible materials



**RECYCLED BASE**

85% recycled black base

new  
**NEW**  
new



ZAG  
CHAMONIX

ZAG  
CHAMONIX

SLAP 112

SLAP 112

**SLAP 112**  
112 CM / 3'8" 1/2  
CHAMONIX SLAP

WEIGHT : 1.100 g  
LENGTH : 182 CM / 5'11" 1/2  
MADE IN SWITZERLAND  
**ZAG:REEN**

# SLAP 112

## The team's favorite !

An excellent float in deep snow. It's the ultimate weapon in the trees and in open powder fields. This ski will help you reach exceptional speeds and cruise in absolute comfort.

GENDER	LENGTH	DIMENSIONS	RADIUS	WEIGHT (-/+)
UNISEX	176	138.5 / 111 / 127	19.5	1.840
UNISEX	182	139.5 / 111 / 128.5	20.5	1.970
UNISEX	188	141 / 112 / 130	22	2.010

### SENSATIONS

Piste aptitude



Freeride aptitude



Uphill aptitude



Grip



Ease of use



### CONSTRUCTION & SHAPE

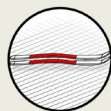

MEDIUM CAMBER

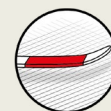

DOUBLE ROCKER



MEDIUM FLEX



MEDIUM CURVE RADIUS

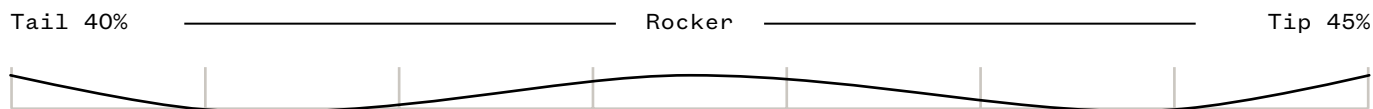

### ZAGREEN PROGRAM



BIO SOURCED RESIN

25% bio-sourced resin



TOPSHEET

50% bio-sourced material

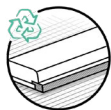

RECYCLED EDGES

The edges are from recycled metal



COTTON BAG

Bio cotton bags packaging



MATERIALS EUROPE

Most performing and eco-responsible materials



RECYCLED BASE

85% recycled black base

new  
**NEW**  
new

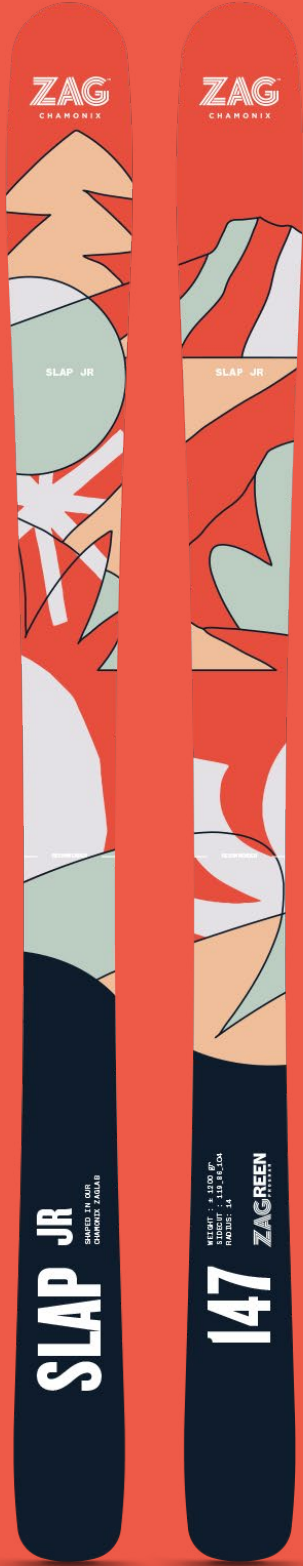

ZAG  
CHAMNIX

ZAG  
CHAMNIX

SLAP JR

SLAP JR

**SLAP JR**  
SHAPED IN OUR  
CHAMNIX ZAGLAB

HEIGHT : 3.100 FT.  
WIDTH : 115-88,5 CM  
LENGTH : 147

**147**  
ZAGREEN

# SLAP JR

**Just like the big boys (or girls) !**

Little brother (or sister) of the SLAP, this ski let's the younger generation challenge the older one on all types of terrain !

GENDER	LENGTH	DIMENSIONS	RADIUS	WEIGHT (-/+)
JUNIOR	137	116 / 81 / 101	12	1.050
JUNIOR	147	119 / 86 / 104	14	1.200
JUNIOR	157	120 / 87 / 105	15	1.350
JUNIOR	165	122 / 89 / 107	16	1.450

## SENSATIONS

Piste aptitude



Freeride aptitude

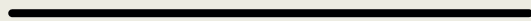

Uphill aptitude



Grip



Ease of use

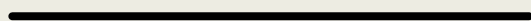

## CONSTRUCTION & SHAPE

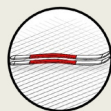

**MEDIUM  
CAMBER**

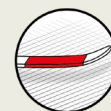

**DOUBLE  
ROCKER**



**MEDIUM  
FLEX**



**SHORT  
CURVE  
RADIUS**



## ZAGREEN PROGRAM



**BIO SOURCED RESIN**

33% bio-sourced resin



**TOPSHEET**

50% bio-sourced material

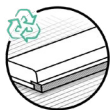

**RECYCLED EDGES**

The edges are from recycled metal



**COTTON BAG**

Bio cotton bags packaging



**MATERIALS EUROPE**

Most performing and eco-responsible materials



ZAG  
CHAMONIX

ZAG  
CHAMONIX

SLAP 104  
Lite

SLAP 104  
Lite

SLAP 104  
LIMITED EDITION

188 LITE

CHAMONIX  
EST. 2002

ZAGREEN  
FACTORY

# SLAP 104 LITE

## Your passport to backcountry adventure !

Enjoy the best mix between the playfulness of our SLAP line and the lightness of a carbon structure. The SLAP 104 LITE is our first twin tip touring ski. It will give you a lot of fun on your way down!

GENDER	LENGTH	DIMENSIONS	RADIUS	WEIGHT (-/+)
UNISEX	170	133.5 / 103 / 122	17	1.560
UNISEX	176	134 / 103 / 123	18.5	1.620
UNISEX	182	136 / 104 / 125.2	19	1.710
UNISEX	188	137 / 104 / 126	20	1.820

**-220g/ski vs  
reg. SLAP 104**

### SENSATIONS

Hard snow aptitude



Deep snow aptitude



Uphill aptitude



Ease of use



### CONSTRUCTION & SHAPE

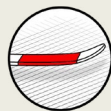

**DOUBLE  
ROCKER**

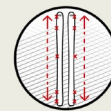

**5 POINTS  
SHAPE**



**STABILITY  
LINK**

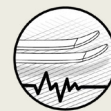

**ADAPTIVE  
ABSORBER**

Tail 25%      Rocker      Tip 30%



### ZAGREEN PROGRAM



**BIO SOURCED RESIN**

25% bio-sourced  
resin



**TOPSHEET**

50% bio-sourced  
material

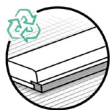

**RECYCLED EDGES**

The edges are  
from recycled  
metal



**COTTON BAG**

Bio cotton bags  
packaging



95%

**MATERIALS  
EUROPE**

Most performing and  
eco-responsible  
materials

**25.26**  
**RESORT**  
**SKIS**





W T A

new NEW

new

T

# HEAVY DUTY<sup>TI</sup> CONSTRUCTION

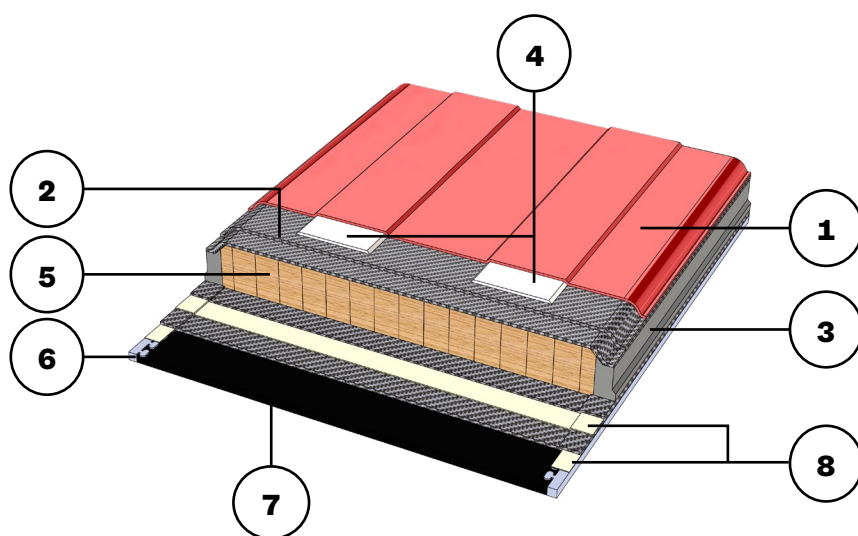

Inserting titanal on our normal heavy duty construction was thought to enhance grip and enhance energy return. This construction is perfect for skis in a carving range that need to be precise. The quadriaxial fiberglass and rubber inserts creates a ski that's comfortable in all types of conditions.

- 1 - Polyamide topsheet : 50% bio-sourced, durability & shiny colors.
- 2 - Quadri-axial fiber : Power and stability.
- 3 - Semi-Cap construction : ABS sidewalls for energy transmission.
- 4 - Titanal inserts : Efficient edge to edge transision and grip.
- 5 - Full poplar wood core : Lightness and resistance.
- 6 - High resitance edges : Durability.
- 7 - Sintered bases : Slide, durability.
- 8 - Rubber : Vibration dampening.

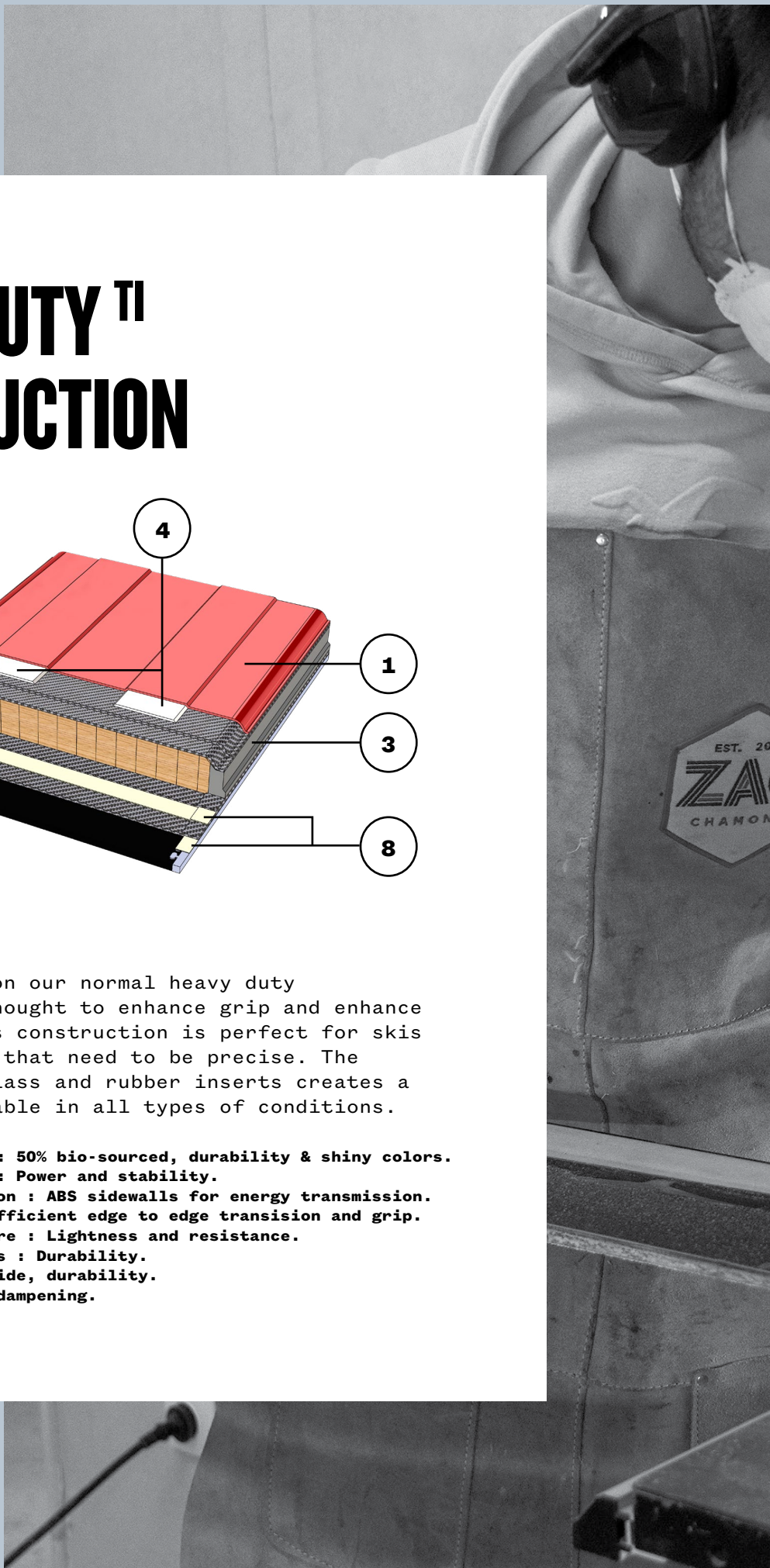



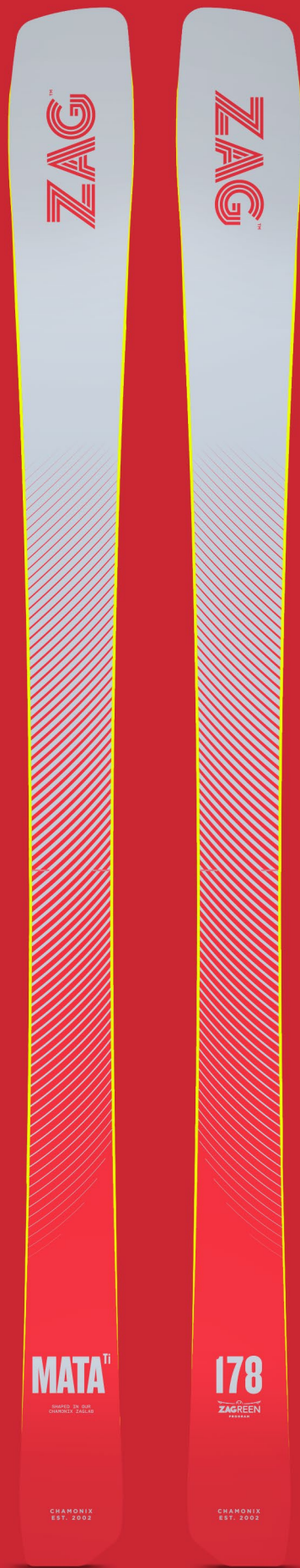

ZAG

ZAG

MATA<sup>Ti</sup>

178

DESIGNED BY ZAG  
POWERED BY ZAGREEN

DESIGNED BY ZAG  
POWERED BY ZAGREEN

CHAMONIX  
EST. 2002

CHAMONIX  
EST. 2002

# MATA<sup>Ti</sup>

**The all-mountain ski that you've never seen before!**

This marks the arrival of a new ski and a new state of mind within the ZAG family. This ski was designed with an explosive asymmetric shape and impressive skiability. 90mm under foot to give it versatility coupled with a titanal plate to let you control the power when you want it. Agressive but not exclusive, carving has never been as enjoyable than with the new MATA Ti.

GENDER	LENGTH	DIMENSIONS	RADIUS	WEIGHT (-/+)
UNISEX	163	135 / 89 / 112	13.8	1.650
UNISEX	168	137 / 89 / 114	14	1.750
UNISEX	173	141 / 90 / 117	14.2	1.850
UNISEX	178	142 / 90 / 119	14.5	1.950
UNISEX	183	143 / 90 / 120	14.7	2.050

### SENSATIONS

Piste aptitude



Freeride aptitude

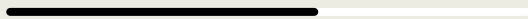

Grip

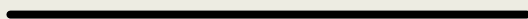

Ease of use



### CONSTRUCTION & SHAPE

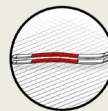

MEDIUM CAMBER



STRONG TORSION



MEDIUM FLEX



SHORT CURVE RADIUS



### ZAGREEN PROGRAM



BIO SOURCED RESIN

25% bio-sourced resin



TOPSHEET

50% bio-sourced material

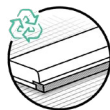

RECYCLED EDGES

The edges are from recycled metal



COTTON BAG

Bio cotton bags packaging



MATERIALS EUROPE

Most performing and eco-responsible materials

25.26

ALL-MOUNTAIN



3-

3-

3-

86

96

106

# HEAVY DUTY CONSTRUCTION

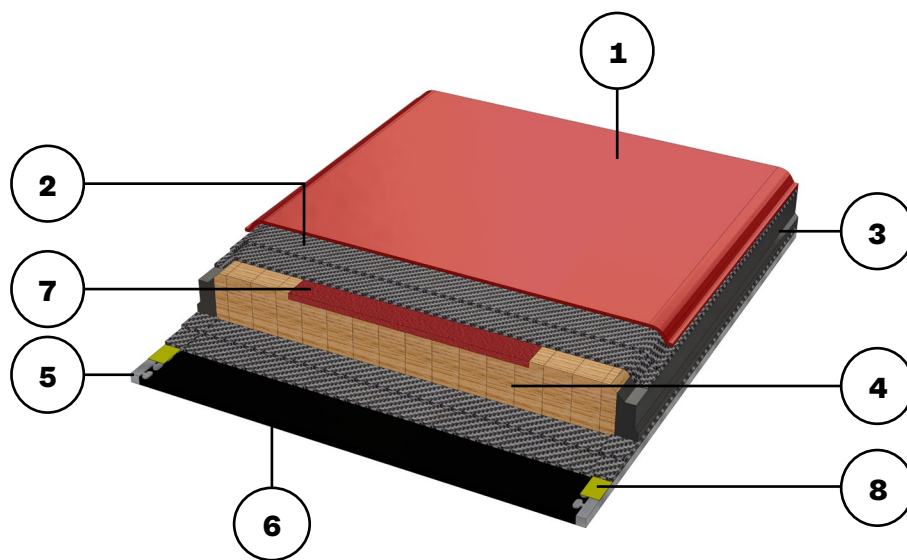

The best compromise between flex and torsion. Composed of double layer multiaxial fiberglass, the objective is to make this ski effective in all types of snow. Based on the legendary H-112, having proven themselves on the feet of our best riders, the heavy duty construction gives skiers maximum safety and reliability. Lightweight for more float but rigid to enjoy the most out of tracked out snow, this construction gives you grip in the toughest of conditions !

- 1 - Polyamide topsheet : 50% bio-sourced, durability shiny colors.
- 2 - Quadri-axial fiber : Stability and resistance.
- 3 - Semi-Cap construction : ABS sidewalls for energy transmission.
- 4 - Full poplar wood core : Lightness and resistance.
- 5 - High resistance edges : Durability.
- 6 - Sintered bases : Slide, durability.
- 7 - Phenol plate : Anti-pullout system for bindings.
- 8 - Rubber : Vibration dampening.





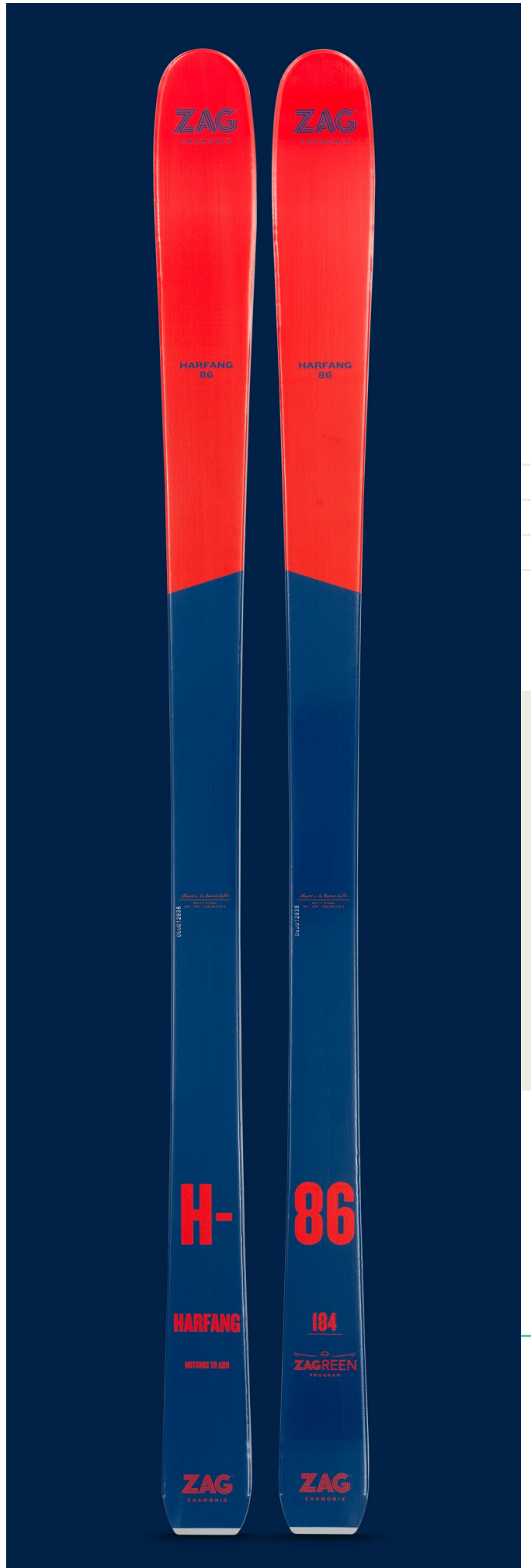
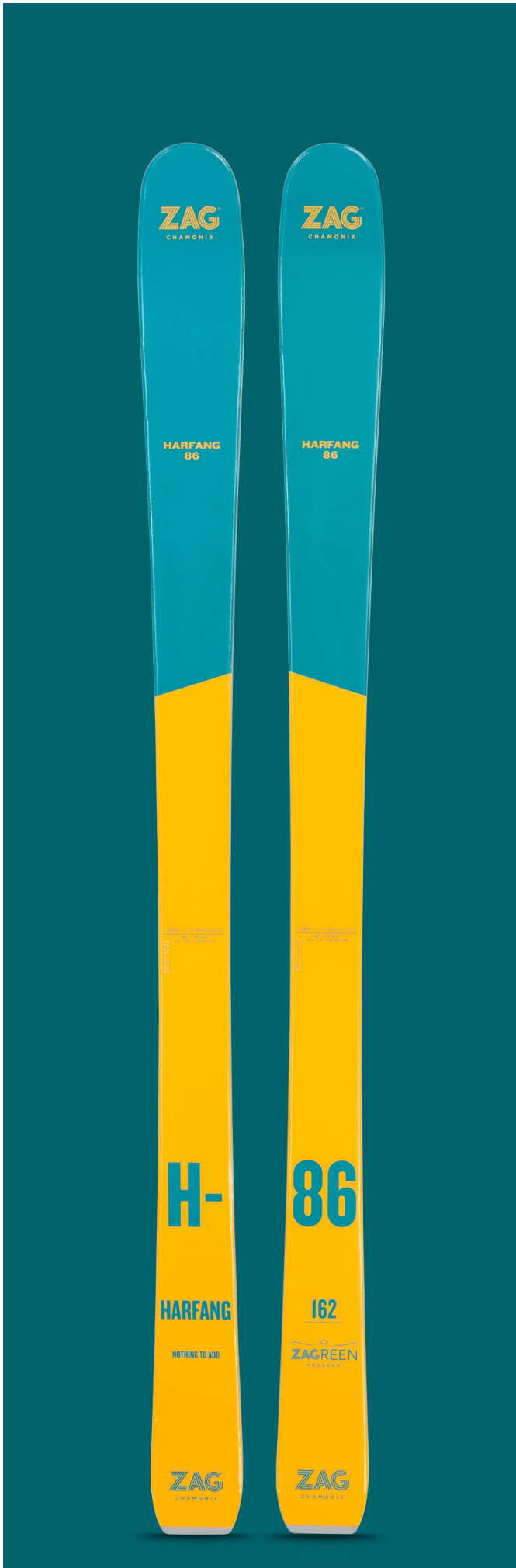

# HARFANG 86

## Cruise in-bounds !

The Harfang 86 is ideal for skiers looking for an on-piste ski perfect for all conditions. Maneuverable and comfortable while carving up the slopes, it'll surprise you even in ungroomed areas.

GENDER	LENGTH	DIMENSIONS	RADIUS	WEIGHT (-/+)
LADY	155	125 / 85 / 108	14	1.460
LADY	162	126 / 85 / 109	15	1.560
LADY & MAN	170	126 / 85 / 111	16	1.640
MAN	177	126 / 86 / 112	17	1.800
MAN	184	129 / 86 / 113.4	18	1.900

### SENSATIONS

Piste aptitude



Freeride aptitude



Grip



Ease of use



### CONSTRUCTION & SHAPE

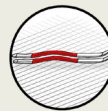

**STRONG CAMBER**

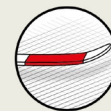

**TIP ROCKER**



**STRONG FLEX**



**STRONG TORSION**



### ZAGREEN PROGRAM



**BIO SOURCED RESIN**

25% bio-sourced resin



**TOPSHEET**

50% bio-sourced material

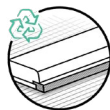

**RECYCLED EDGES**

The edges are from recycled metal



**COTTON BAG**

Bio cotton bags packaging



**MATERIALS EUROPE**

Most performing and eco-responsible materials



**RECYCLED BASE**

85% recycled black base

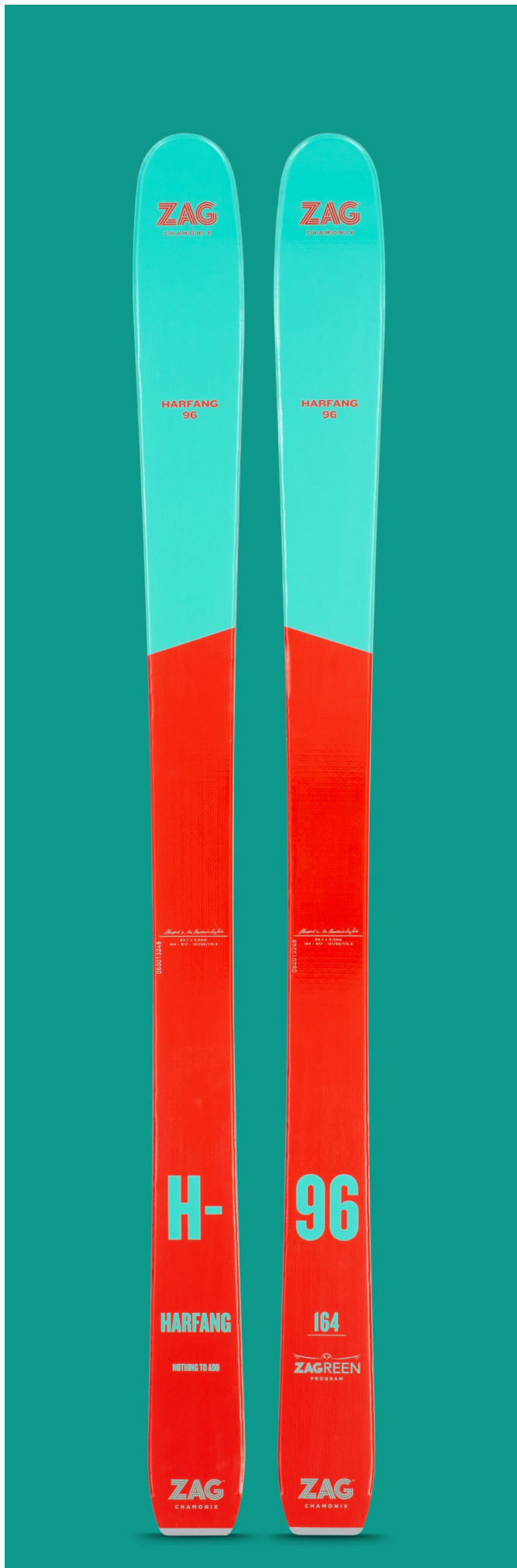

# HARFANG 96

**From carving to large powder turns !**

The 4x4 ski that's excellent on and off the groomers. It's characterized by its excellent grip on hard snow and its exceptional ease in powder.

GENDER	LENGTH	DIMENSIONS	RADIUS	WEIGHT (-/+)
LADY	156	127 / 94 / 111.5	15.5	1.590
LADY	164	131 / 96 / 115.5	17	1.620
LADY & MAN	170	131 / 96 / 115.5	17.5	1.760
MAN	176	131.5 / 96 / 116	18.5	1.900
MAN	182	132.5 / 96 / 117	20	2.050
MAN	188	133.5 / 96 / 118	21	2.150

## SENSATIONS

Piste aptitude



Freeride aptitude



Grip

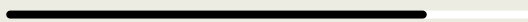

Ease of use

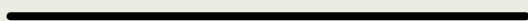

## CONSTRUCTION & SHAPE

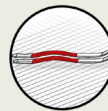

**STRONG CAMBER**

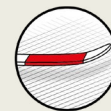

**DOUBLE ROCKER**



**MEDIUM FLEX**



**MEDIUM TORSION**



## ZAGREEN PROGRAM



**BIO SOURCED RESIN**

25% bio-sourced resin



**TOPSHEET**

50% bio-sourced material

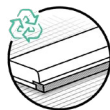

**RECYCLED EDGES**

The edges are from recycled metal



**COTTON BAG**

Bio cotton bags packaging



**MATERIALS EUROPE**

Most performing and eco-responsible materials



**RECYCLED BASE**

85% recycled black base

ZAG  
CHAMONIX

ZAG  
CHAMONIX

HARFANG  
106

HARFANG  
106

*Allegria in the Mountains by ZAG*  
SALICOR 2014  
178 - 800 - 3377108/112

*Allegria in the Mountains by ZAG*  
SALICOR 2014  
178 - 800 - 3377108/112

H-

106

HARFANG

178

NOTHING TO ADD

ZAGREEN  
PROGRAM

ZAG  
CHAMONIX

ZAG  
CHAMONIX

# HARFANG 106

**The ultimate weapon for serious freeriders !**

A worthy successor to the legendary H-112, this ski is a clever blend between power and playfulness! It responds to the needs of freeriders chasing after fast paced skiing.

GENDER	LENGTH	DIMENSIONS	RADIUS	WEIGHT (-/+)
UNISEX	178	137 / 106 / 122	20	2.000
UNISEX	186	139.5 / 106 / 124.5	21.5	2.150
UNISEX	192	140.5 / 106 / 125.5	22.5	2.300

## SENSATIONS

Piste aptitude

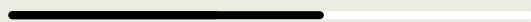

Freeride aptitude

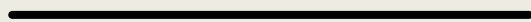

Grip

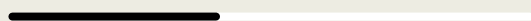

Ease of use

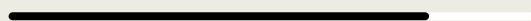

## CONSTRUCTION & SHAPE



**MEDIUM CAMBER**

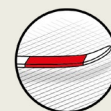

**DOUBLE ROCKER**



**STRONG FLEX**



**MEDIUM TORSION**



## ZAGREEN PROGRAM



**BIO SOURCED RESIN**

25% bio-sourced resin



**TOPSHEET**

50% bio-sourced material

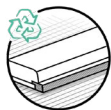

**RECYCLED EDGES**

The edges are from recycled metal



**COTTON BAG**

Bio cotton bags packaging



**MATERIALS EUROPE**

Most performing and eco-responsible materials



**RECYCLED BASE**

85% recycled black base

**25.26**  
**ACCESSORIES**  
**RANGE**

# AUGUST

# SOB





LES

POLES

SKINS

BINDINGS

APPAREL

# POLES

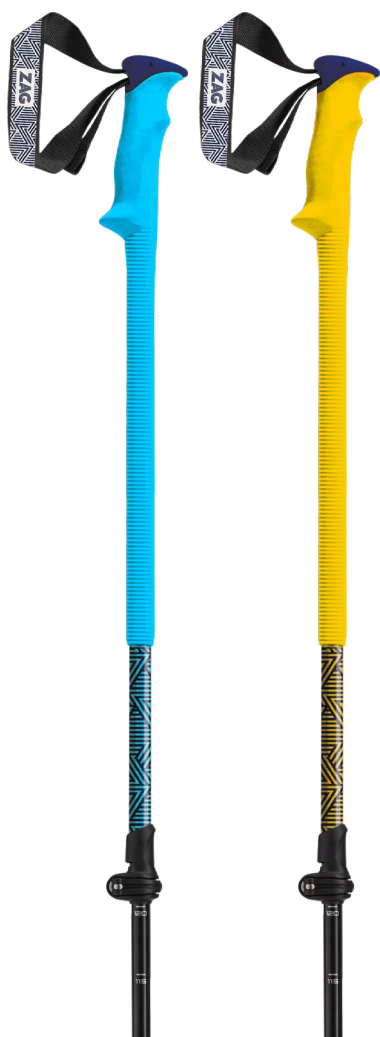

## NORTH POLE

245gr  
**Vario** : 105 to 140 cm  
Available in two colors

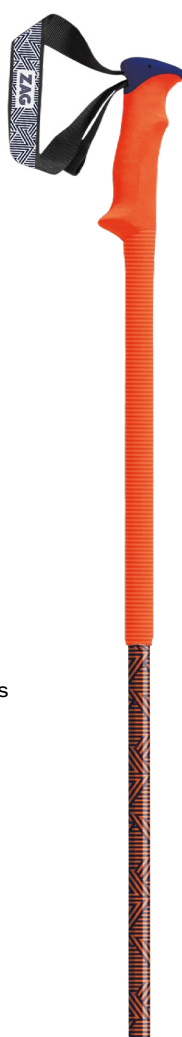

## SOUTH POLE

200gr (size 120cm)  
**Sizes** : 110, 115, 120, 125, 130 cm

## CONSTRUCTION & SHAPE



### Z SAFE SYSTEM

Grip and easily adjusting strap with safety release.



### ERGO GRIP

Ergonomic handle material EVA anti slip and ultra-comfort.



### LIGHTNESS & RESISTANCE

Aluminium Grad Aéro Spatial.

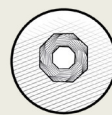

### BASKET

Large & soft basket for hanging in the backs.



### TUNGSTEN TIP

Long and durable tip.



# SKINS



## POMOCA x ZAG

Composition : 70% Mohair, 30% Nylon  
 Designed for experienced ski tourers and amateur competitors, the Climb Pro Glide mixed structure skin is ideal for multi-day expeditions, offering extra performance and gliding qualities.

## PERFORMANCE

The polyvalent Climb Pro Glide combines excellent gliding performance, good traction and utmost resistance. Extremely versatile use, ranging from competition to long-term touring.

## QUALITY

Best gliding mix skin ever, best anti-glopping skins, very resistant: the skin for professionals.



Hook for Adret



Hooks for Ubac

### MODELS      SIZES (cm)

<b>Adret 78</b>	165 / 170 / 176
<b>Adret 85</b>	155 / 160 / 166 / 172 / 178
<b>Ubac 89</b>	156 / 164 / 171 / 176 / 183
<b>Ubac 95</b>	158 / 164 / 170 / 174 / 178 / 184
<b>Ubac 102</b>	164 / 170 / 176 / 184 / 188
<b>Ubac 112</b>	176 / 184
<b>Slap</b>	<b>S</b> = 160 - 164 <b>M</b> = 166 - 176 <b>L</b> = 176 - 188



# BINDINGS TOURING

## ZAG HAUTE ROUTE 10 PLUS



**170 Grams**

**Materials :** Alu 7075, POM, Stainless steel

**Release :** 5-10

**Adjustment :** 30 mm

**Optional Ski Brake :** Touring ski brake (R15)

**Walking modes :** Flat, +37, +43.5, +54.5, +58.5 mm

**Speed Kit (+59gr) :** with R01 heel adjustment plate / crampon slot / kevlar core leash

## ZAG RAIDER II EVO

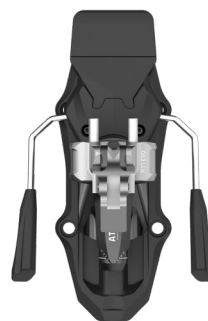
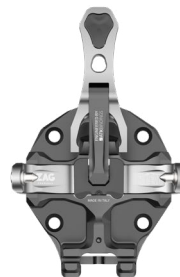

**370 Grams**

**Materials :** Alu 7075, POM, Stainless steel

**Toe & Heel Release :** 3-11

**Adjustment :** 25 mm

**Ski brake :** 86 mm to 120 mm

**Walking modes :** Flat, +31, +51 mm

**Heel elastic travel :** 14mm (E.R.S)

## ZAG RENT ME 10 AP

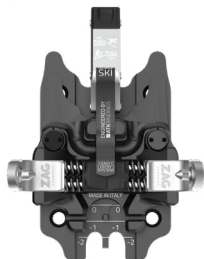

**380 Grams**

**Materials :** Alu 7075, POM, Stainless steel

**Release :** 5-10

**Adjustment :** 80 mm (30mm toe, 50mm heel)

**Ski brake :** 86 mm to 120 mm

**Walking modes :** Flat, +36, +51 mm

**Heel elastic travel :** 12 mm (E.R.S)

# BINDINGS ALPIN

**SALOMON  
NR MII  
GW**



**860 Grams**

DIN : 3,5-11

**SALOMON  
STRIVE  
13 DEMO  
GW**



**1020 Grams**

DIN : 4,5-13

**SALOMON  
NR 5 JR**



**1010 Grams**

DIN : 1-5

# SIZE GUIDE

YOU'LL SEE, IT'S VERY EASY TO APPLY!

## EXAMPLE :

Your size [a] : 173 cm / Your level [b] : Expert

Choose your ski range and model : HARFANG 96

Calculate :

I'm 173 cm and I'm an Expert [-2 ou +8] :

173 - 2cm = 171 cm or 173 + 8cm = 181 cm

Two sizes could correspond : 170cm & 176cm

Find the box in the table that corresponds to you.

These indications are only theoretical, often all is not played with a few centimeters.

To find the best size, please refer to the advice of the pro in a retail store (list available on our website).

		BEGINNER / INTERMEDIATE		ADVANCED		EXPERT	
<b>MATA</b>	<b>Ti</b> (163, 168, 173, 178 cm)	-10	-5	-10	0	-8	4
<b>ADRET</b>	<b>78</b> (165, 170, 176 cm)	-12	0	-10	0	-10	0
	<b>85</b> (155, 160, 166, 172, 178 cm)	-10	0	-7	0	-5	5
<b>UBAC</b>	<b>89</b> (156, 164, 171, 176, 183 cm)	-8	0	-5	0	-3	5
	<b>95</b> (158, 164, 170, 174, 178, 184 cm)	-8	0	-5	2	-3	5
	<b>102</b> (164, 170, 176, 184, 188 cm)	-5	0	-5	5	-2	7
	<b>112</b> (176, 184 cm)	-5	0	-5	5	-2	7
<b>HARFANG</b>	<b>86</b> (155, 162, 170, 177, 184 cm)	-8	-3	-5	0	-3	5
	<b>96</b> (156, 164, 170, 176, 182, 188 cm)	-5	-2	-4	5	-2	8
	<b>106</b> (178, 186, 192 cm)	-5	0	0	7	0	10
<b>SLAP</b>	<b>92</b> (160, 166, 173, 178, 185 cm)	-5	2	0	5	0	10
	<b>98</b> (160, 166, 173, 180, 187 cm)	-5	2	0	5	0	10
	<b>104</b> (164, 170, 176, 182, 188 cm)	-5	2	0	5	0	10
	<b>112</b> (164, 170, 176, 182, 188 cm)	-5	2	0	5	0	10







# ORGANIZATION CHART

## EXECUTIVE MANAGEMENT



**CAROLINE DE WAILLY**

CEO

caroline@zagskis.com



**CLAIRE-EMILIE CAURETTE**

Operations & organisation  
Director

claire-emilie@zagskis.com

## SUPPLY CHAIN & FINANCE DEPARTMENT



**BLANDINE PASSOT**

ADV & Customer Service  
Director

logistique@zagskis.com



**CLAIRE-EMILIE CAURETTE**

Financial & HR  
Director

claire-emilie@zagskis.com



**CAMILLE PICHOT**

ADV Web  
SAV

sales@zagskis.com



**HANNAH ZERMATTEM**

Financial  
Assistant

comptabilite@zagskis.com

## SALES DEPARTMENT



**JEAN-BAPTISTE PETIT**

Sales  
Director

jb@zagskis.com



**THOMAS CHABOT**

France Sales  
Manager

thomas@zagskis.com

## R&D DEPARTMENT



**BASTIEN SAILLARD**

R&D  
Director

bastien@zagskis.com



**PAUL CHEVALLOT**

R&D  
Assistant

zaglab@zagskis.com

## CONCEPT STORE



**ALLAN ROY**

Proshop ZAG  
Manager

proshop@zagskis.com

## MARKETING DEPARTMENT



**ALAN LEMASSON**

Marketing  
Director

alan@zagskis.com



**THÉO VOINCHET**

Activation Marketing  
Manager

theo@zagskis.com



**MARINE TESTOU**

Promotion & Events  
Manager

events@zagskis.com



**JÉRÔME BRULEY**

Marketing Design  
Manager

design@zagskis.com



**GABIE OTTOU**

Digital Marketing  
Assistant

gabie@zagskis.com

# AGENTS & DISTRIBUTORS

## EUROPE

### AUSTRIA

---

#### AGENT - AUSTRIA WEST / TYROL

Stephan Mitter  
stephanmitter@me.com  
+43 664 221 5047

#### AGENT - AUSTRIA EAST

Gerald Stelzig  
agentur-stelzig-alpin  
Mobil: +43 664 4034567  
Mail: ct.stelzig@gmail.com

### BULGARIA

---

#### DISTRIBUTOR - NOMADIA

Orlin  
office@nomadia.bg  
+359 89 683 4018

### BENELUX

---

#### AGENT - MINDSHAKE

Dimitri Papageorges  
dimitri@mindshake.biz  
+32 475 77 0570

### CZECH/SLOVAKIA

---

#### DISTRIBUTOR - HUDYSPOKT

Jakub Tausner  
jakub.tausner@hudy.cz  
+420 770 160 344

### FRANCE

---

#### FRANCE SALES MANAGER ZAG

Thomas Chabot  
thomas@zagskis.com  
+33 785 802 236

#### AGENT - SOUTH ALPES

Simon Valle  
simon@zagskis.com  
+33 6 63 11 82 27

#### AGENT - PYRÉNÉES

Mathias Bertoux  
mathias.bertoux@gmail.com  
+33 6 09 87 15 46

#### AGENT - AUVERGNE - RHÔNE ALPES

Mick Midali                      Peio Lafourcade  
mick@zagskis.com              peio@zagskis.com  
+33 6 89 17 60 08              +33 6 85 80 01 27

### GERMANY

---

#### AGENT - OUTDOOR AGENTUR UP

Christian Neiger  
kontakt@outdoor-agentur-up.de  
+49 179 49 38 391

### GEORGIA

---

#### DISTRIBUTOR - MPLUS

David Chichinadze  
suppliers@mplus.ge  
+995 599 22 58 72

### ITALY

---

#### AGENT - B-FACTORY

Alessandro Lafranconi  
alessandro.lafranconi@b-factory.it  
+39 333 654 8919

### POLAND

---

#### DISTRIBUTOR - MALCZEWSKI SPORT

Marcin Malczewski  
malczewskisport@gmail.com  
+48 609 603 034

### SERBIA

---

#### DISTRIBUTEUR - GRACHEV NIKOLAI

Grachev Nikolai  
0135529@gmail.com

### SWEDEN

---

#### DISTRIBUTOR - RAW LIMITS

Henrik Selander  
henrik@rawlimits.se  
+46 70 915 18 50

### SPAIN

---

#### DISTRIBUTEUR - FREE4RIDE

Manolo Copano                      Hug Calvete  
manolocopano@gmail.com              hug@free4ride.es  
+34 660 13 19 80                      +34 636 80 92 40

### SWITZERLAND

---

#### DISTRIBUTOR - NEW ROCK DISTRIBUTION

New Rock SA  
info@newrocksport.ch  
+41 91 935 14 00

## **NORTH AMERICA**

### **USA**

---

#### **SALES TEAM ON THE GROUND**

### **CANADA**

---

#### **DISTRIBUTOR - COAST MOUNTAIN COLLECTIVE**

Jens Ourom  
team@coastmountaincollective.ca  
+1 (604) 357 3987

## **SOUTH AMERICA**

### **ARGENTINA**

---

#### **DISTRIBUTOR - AVALANCHA**

Lucas Rossini  
rossiniacul@hotmail.com  
+54 9 294 441 9927

## **REST OF THE WORLD**

### **AUSTRALIA**

---

#### **AGENT - STRANDS GEAR**

Adam Gill

### **JAPAN**

---

#### **DISTRIBUTOR - STRANDS GEAR**

Tadashi Sekine  
tad@strandsgear.com

### **NEW-ZELAND**

---

#### **AGENT - LITTLE DAHU LTD**

Jeremy Serre  
littledahu.nz@gmail.com  
+64 2 116 945 76

---

#### **INTERNATIONAL SALES MANAGER ZAG**

Jean-Baptiste Petit  
jb@zagskis.com  
+33 695 987 804



+33 450 347 578  
2100 Route d'Argentière  
74400 Chamonix Mont-Blanc  
FRANCE  
info@zagskis.com

[WWW.ZAGSKIS.COM](http://WWW.ZAGSKIS.COM)

 @zagskis.com

**ELEVATE  
YOUR SENSATIONS**